

Mid-West[®] Instrument

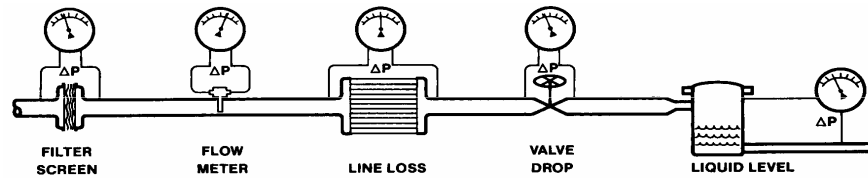

MODEL 142: "DELTA METER"[®] Installation and Operating Instructions

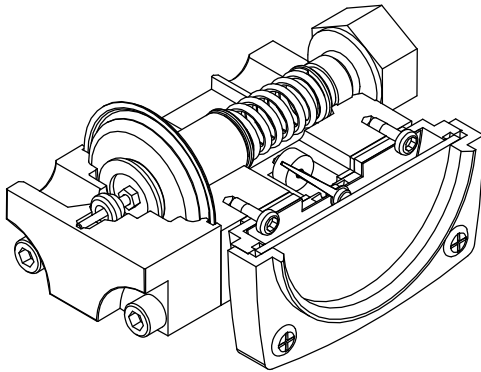

INSPECTION

Before installation check the nameplate on each instrument against the receiving paperwork and the intended application for correct part number, materials of construction, working pressure, dial range, etc. If equipped with switches, check electrical rating. Inspect for shipping damage and, if damaged, report it immediately.

NOTE - Before attempting repairs contact your local Mid-West Representative or our factory. Failure to do so will void any warranty.

PRODUCT DESCRIPTION

The Model 142 "Delta Meter"[®] is a medium range differential pressure instrument available as a switch, a gauge, or both. See the "Part Numbering System", (Fig. TBD) for available options.

A flexible elastomer diaphragm and calibrated range spring are moved by differential pressure. A pair of magnets, coupled with the diaphragm, transmit this motion through the wall of the pressure housing to a follower magnet attached to an indicating pointer. The rotation of the follower magnet causes the pointer to track the movement of the internal magnet and indicate the differential on the dial scale.

INSTALLATION

The model 142 is calibrated and tested prior to shipment and is ready for immediate installation. Use of the following installation procedures should eliminate potential damage and provide optimum trouble-free operation.

1. PROCESS CONNECTIONS

1/4" FNPT are provided as standard however check the paperwork for the connections ordered. There are two connections on the housing identified as "hi" and "lo" for high pressure and low pressure. Be sure these get plumbed to the proper connections on your system. Improper connection will not damage the instrument, but it will not function properly. Flexible tubing is recommended to minimize effect of possible vibration.

2. INSTRUMENT LOCATION

On liquid service the instrument should be mounted **below** the process connections to facilitate self-bleeding. On gas service it should be located **above** the process connections to promote self-draining. If the process contains particulates, a "pigtail" loop or drop leg (manometer "U-tube" configuration) in the tubing will minimize the possibility of it migrating into the instrument.

3. PANEL MOUNTING

Gauges with 2-1/2" dials can only be mounted through the **rear** of the panel. Make the proper panel cutout as indicated in (Fig .TBD). Remove the (4) bezel screws. Insert the gauge front through the rear of the panel and reinstall the bezel screws through the front of the panel and into the gauge bezel. Tighten the screws securely, alternating in a **diagonal** pattern.

Gauges with a 3 1/2 " dial must be mounted from the front of the panel. Contact the factory for mounting information and dimensional data.

Gauges with 4-½" dial should be mounted from the **front** of the panel. Make the cutout as indicated in (Fig. TBD). Insert the (4) panel mounting studs, finger tight, into the metal inserts located in the rear of the bezel. Insert the gauge through the panel, aligning the panel mounting studs with the holes in the panel. Install the (4) #8-32 nuts onto the studs and tighten securely.

4. PIPE MOUNTING

An optional pipe mounting kit is available for mounting the gauge to a 2" vertical or horizontal pipe.

TROUBLESHOOTING

1. Gauge does not indicate differential.

- A. Check for proper hook up, high to "hi" low to "lo".
- B. Make certain block valves are open and that the equalizer (balance) valve is closed (if using a 3 valve manifold).
- C. If A & B check out correctly, loosen high-pressure line to determine if there is pressure to the instrument.
- D. Verify gauge is not in an electromagnetic / magnetic environment. i.e.; close proximity to high current power lines.
- E. If there is pressure to the instrument, check to determine that there is differential across the unit being monitored. If so, contact the factory for assistance and/or and "RGA" (Return Goods Authorization) number to return the instrument for repair or replacement.

DIMENSIONAL INFORMATION

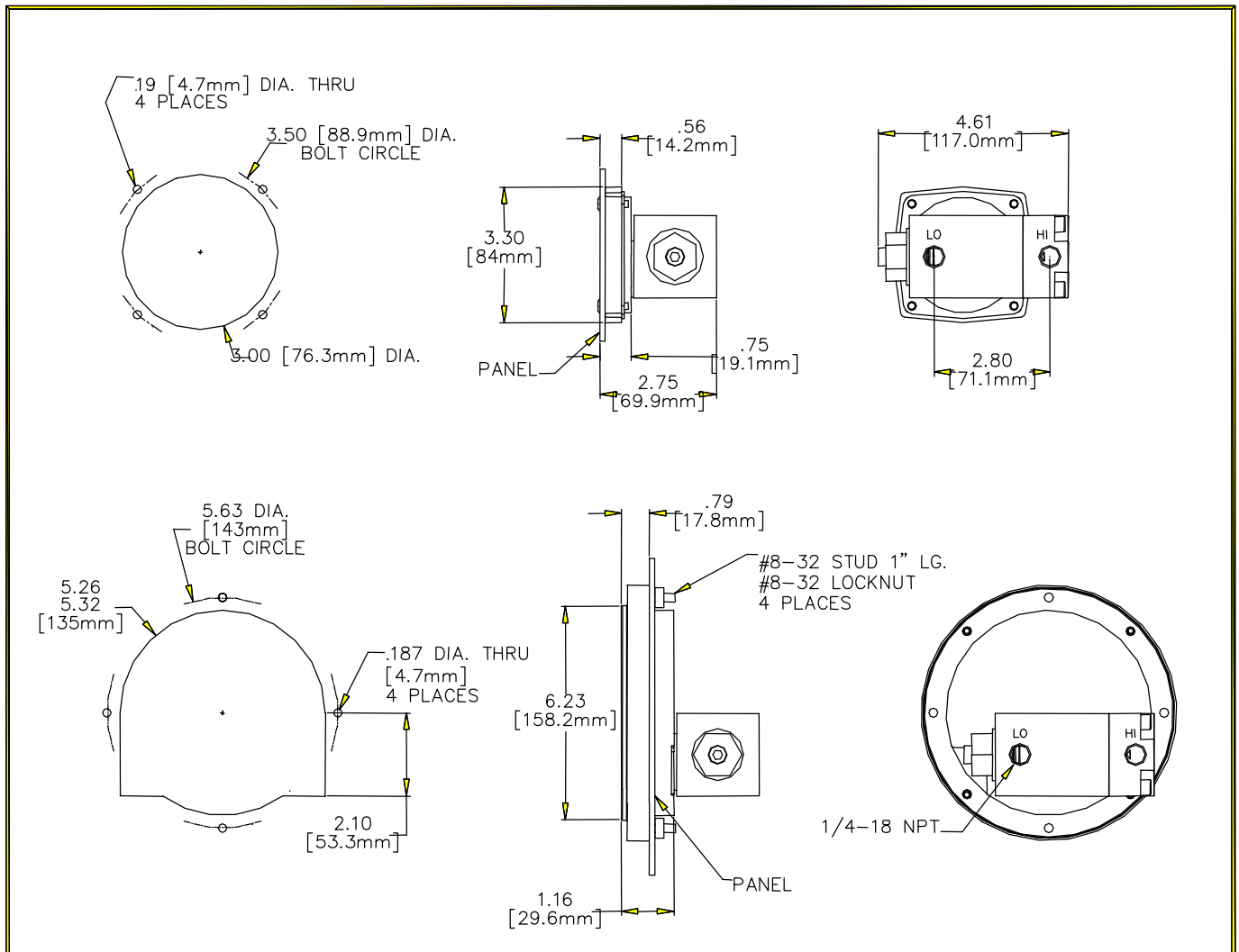

Part Numbering System

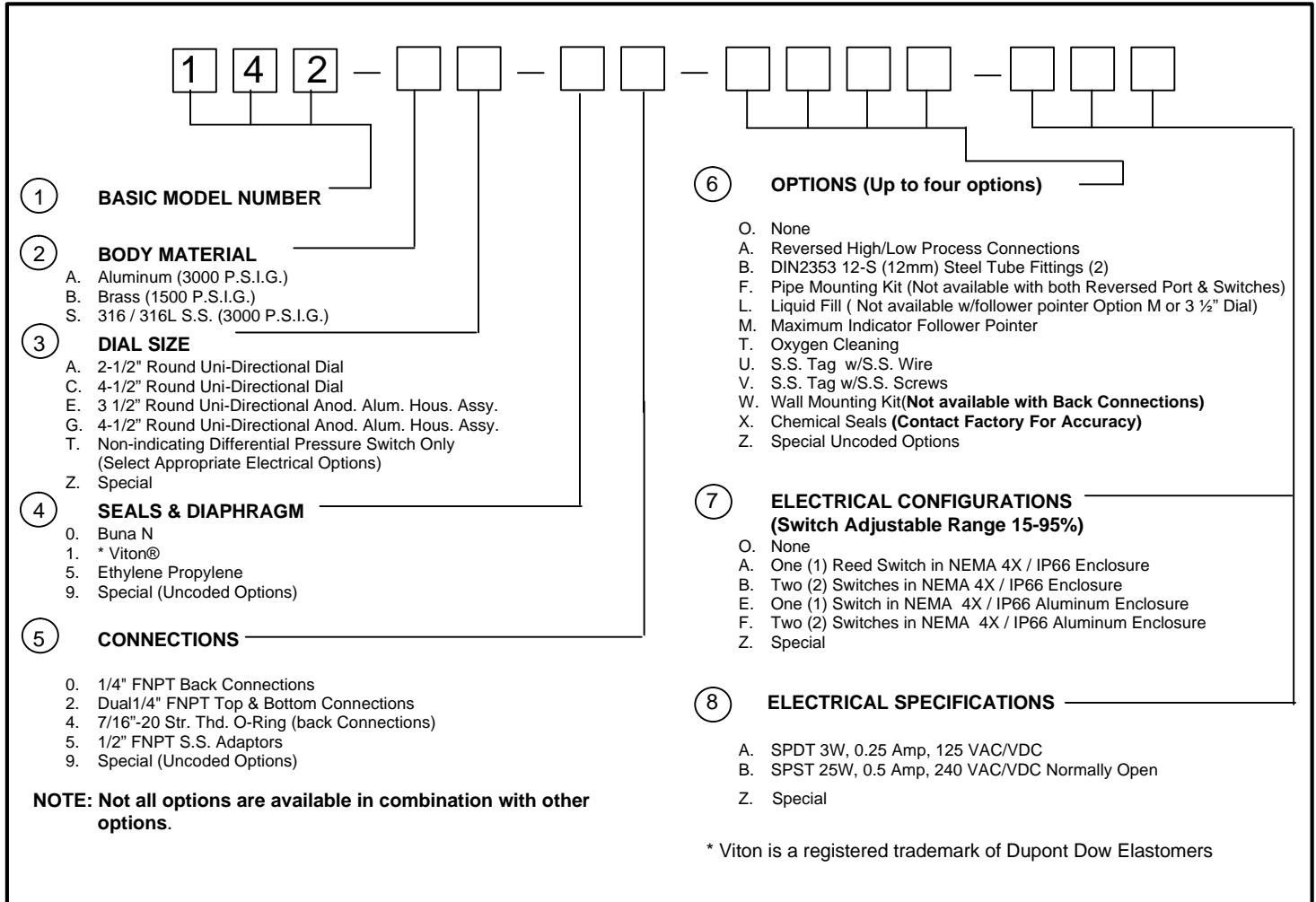

PROOF PRESSURE: Two times the working pressure or 6000 PSI, whichever is lower at ambient temperature.

TEMPERATURE LIMITS: -40 °F (-40° C) to 200°F (93°C). These limits are based on the entire instrument being saturated to these temperatures. System (process) temperatures may exceed these limitations with proper installation. Contact our customer service representative for details.

STANDARDS: All Model 142 Series differential pressure gauges either conform to and/or are designed to the requirements of the following standards:

ASME B1.20.1	NACE MR0175
ASME B40.1	NEMA Sts. 250
EN-61010-1	UL Std. No. 50 & 508
CSA-C22.2 No. 14,& 25	

CE Marking Statements:

This product shall not be placed in an Explosive atmosphere as defined by the ATEX Directive 94/9/EC Evaluation to the directive's requirements is in process.

The Pressure Equipment Directive has been determined to be **non applicable for CE marking**. These products are manufactured in accordance with article 3, paragraph 3 of the directive, "sound engineering practice". They fall below category I for non-hazardous gases, hazardous liquids, & non-hazardous liquids. This product also falls below category I for hazardous gases at or below 200 bar.

Mid-West®

Instrument

6500 Dobry Dr. Sterling Heights, MI 48314

Ph: (586)254-6500 FAX (586)254-6509

E-Mail: sales@midwestinstrument.com

Web Page: www.midwestinstrument.com